

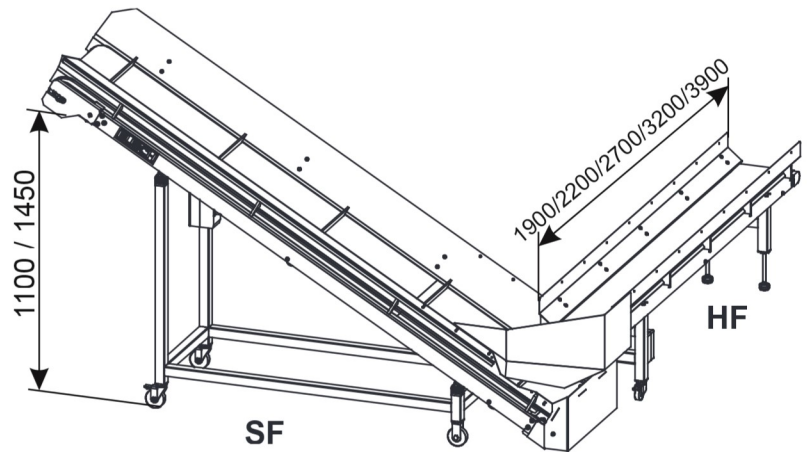

WASTE CONVEYORS

model series SF and SF-ASE

Technical data		SF 130/25 -225	SF 160/25 -225	SF 110/50 ASE	SF 145/50 ASE	HF 00/25 -190	HF 00/25 -220	HF 00/25 -270	HF 00/25 -320	HF 00/25 -390
Conveying height	mm	1300	1600	1100	1450	-	-	-	-	-
Length of delivery chute	mm	2250	2250	-	-	1900	2200	2700	3200	3900
Conveying speed										
at 50 Hz	m/s	0,4	0,4	0,4	0,4	0,3	0,3	0,3	0,3	0,3
Power requirements: 3-phase current	kW	0,25	0,25	0,25	0,25	0,1	0,1	0,1	0,1	0,1
Power consumption 230 V / 400 V	A	1,0	1,0	1,0	1,0	0,25	0,25	0,25	0,25	0,25
Measurements and weights										
Length	mm	4235	4745	2365	2990	2110	2420	2940	3450	4080
Height	mm	1665	1960	1440	1815	490	490	490	490	500
Width	mm	520	520	645	645	325	325	325	330	335
Net weight	kg	107	123	80	127	45	49	56	67	79

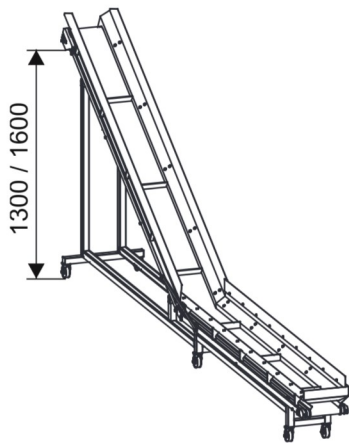

Gerhard Busch GmbH

Brookdamm 28 | D-21217 Seevetal | Germany
Tel. +49 (0)40 769159-0 | Fax +49 (0)40 769159-33
info@buschgraph.de | www.buschgraph.de

Stanzmaschinen Die-Cutting Machines
Bündelmaschinen Banding Machines
Späneförderbänder Waste Conveyors
Stapelwender Pile Turners
Schneidemaschinen Guillotines
Schneidperipherie Peripherals for Guillotines